

# Stacking and Wrapping New and Used Batteries on Pallets

THESE GUIDELINES ARE TO ASSIST IN COMPLIANCE WITH FEDERAL DEPARTMENT OF TRANSPORTATION (USDOT) REGULATIONS<sup>1</sup>. PLEASE ASSIST THE DRIVER IN COMPLYING WITH THE LAW. FAILURE TO COMPLY WITH THE GUIDELINES CAN RESULT IN REFUSAL BY THE CARRIER TO ACCEPT MATERIAL. IN ADDITION, FAILURE TO COMPLY CAN RESULT IN FINES AND PENALTIES FROM FEDERAL, STATE, AND LOCAL AUTHORITIES.

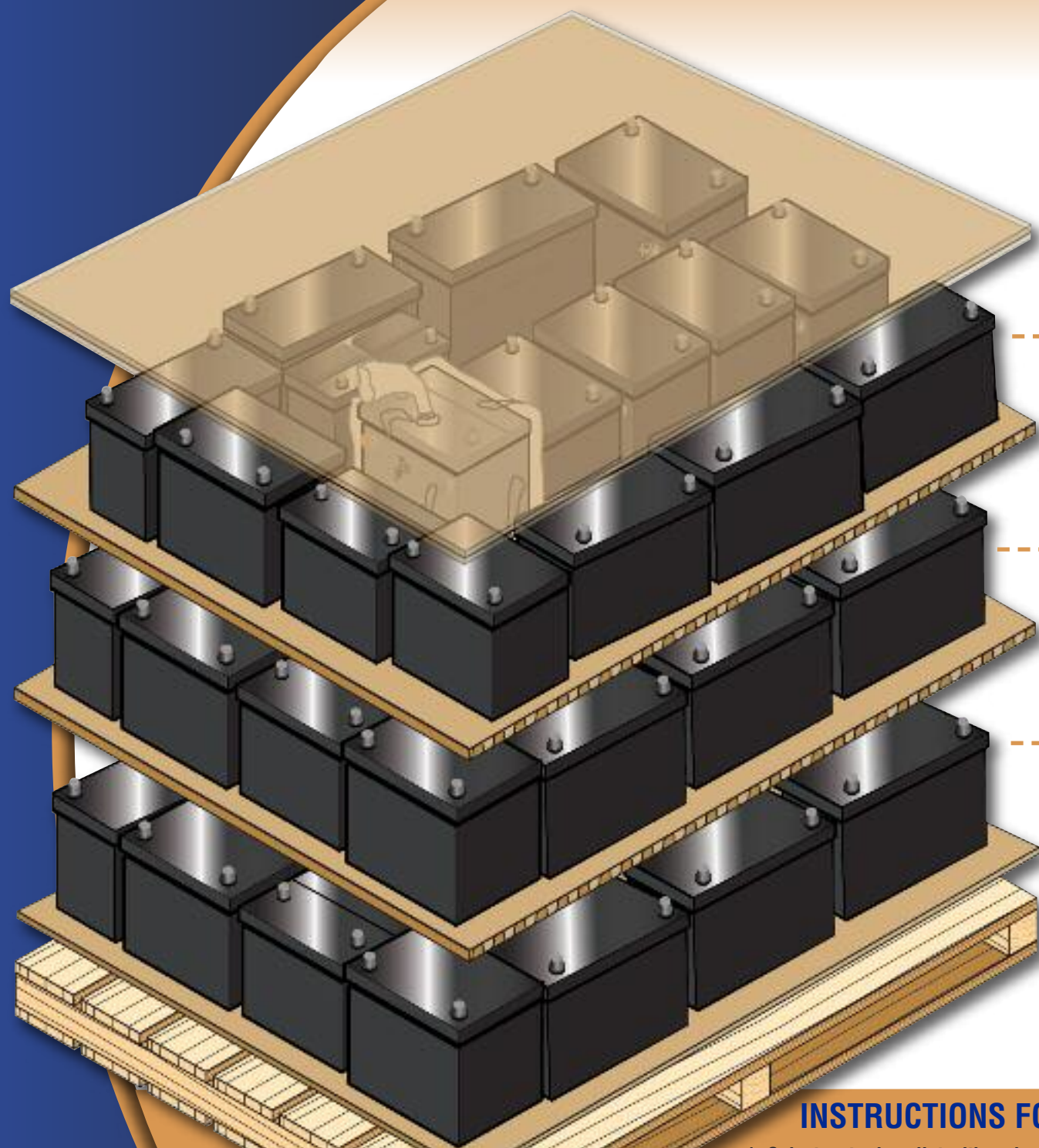

WAFFLEBOARD OR SHEETS OF CARDBOARD\*

BATTERIES

WAFFLEBOARD PREFERRED\*  
(MINIMIZES POTENTIAL FOR POST PENETRATION AND SHORT CIRCUIT)

BATTERIES

WAFFLEBOARD PREFERRED\*  
(MINIMIZES POTENTIAL FOR POST PENETRATION AND SHORT CIRCUIT)

BATTERIES

CARDBOARD

PALLET

\* See item 4 and 7 under Stacking Pallet Instructions

## IMPORTANT GENERAL HANDLING REQUIREMENTS

Before handling batteries, please read and adhere to all of the following requirements:

- Wear the appropriate personal protection equipment.
- Handle all returned batteries with the same responsible care as new batteries.
- Keep batteries upright at all times. Do not tip over on side or upside down.
- Do not throw or drop batteries. Put batteries carefully down on pallet.

## IMPORTANT PALLET SPECIFICATIONS

- Maximum pallet sizes: 44" x 48" or 40" x 48"
- Maximum weight per pallet: Approx. 3600 lbs.
- Maximum layers per pallet: 3
- Only lead-acid batteries may be returned, including AGM and gel lead-acid batteries
- Pallet must be constructed with a minimum of three bottom boards and durable enough to handle the battery load.
- Stack return battery pallet using pallet provided with new shipment if possible.



www.batterycouncil.org

These guidelines were developed by a committee of industry experts and are believed adequate to assure compliance with USDOT requirements effective as of December, 2010. However, especially if an incident occurs in transit, regulatory authorities may challenge the adequacy of your packaging and load securing notwithstanding your compliance with these guidelines. Seek legal advice if you have any questions about these issues.

## INSTRUCTIONS FOR WRAPPING PALLET

All batteries must be secured to the pallet with stretch wrap. Stretch wrap works best if it is pulled tight before stretching it around the corners. Figure 4 shows a properly wrapped pallet.

1. Start with the stretch wrap turned sideways to create a rope effect (see fig. 1). Wrap around the top layer four or five times.\*
2. Still using the rope effect, wrap the top layer twice\* again, crossing over the top each time to form an "X-pattern." This will pull the batteries towards the center to prevent batteries from falling off of the pallet, a DOT requirement.
3. Hold the stretch wrap open (see fig. 2 and 3), wrap around the bottom layer four to five times\*, being sure to catch the edges of the pallet.
4. Finally, after placing cardboard on top of the batteries, wrap around the top layer four or five times\* with the stretch wrap in the open effect and tear at the last corner.

\* Wrap as many times as necessary to stabilize the load

<sup>1</sup> Title 49 C.F.R. 173.159 Batteries, Wet

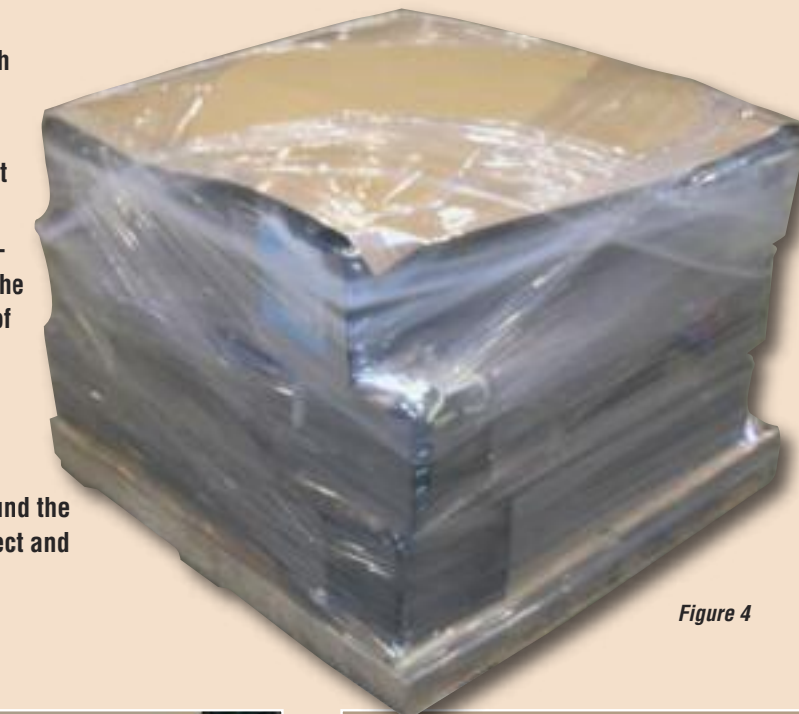

Figure 4



Figure 1



Figure 2

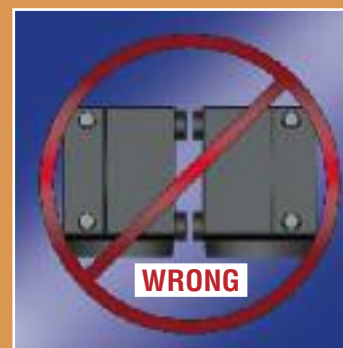

Figure 3

## INSTRUCTIONS FOR STACKING PALLET

1. Select a sturdy pallet with no broken or missing boards. Be sure there are no nails sticking up, which could puncture the batteries. Stack return battery pallet using pallet provided with new shipment if possible.
2. Place a layer of cardboard on the pallet to prevent the batteries from sliding off of the pallet.
3. Make the first layer of batteries level and as close together as possible. If some of the batteries are shorter, they should be placed in the center of layers. Any taller batteries should be placed on the top layer.
4. Place waffleboard (preferred) or sufficient cardboard (multiple sheets if necessary) between all layers, including the top layer of batteries to prevent the possibility of puncturing the batteries above and short circuit. Place cardboard on top of pallet.

5. Side terminal batteries must be stacked so the posts are facing away from each other and not facing towards the outside of the pallet. Side terminals must never touch.



6. Top posts must be positioned toward the outside of the pallet so the layer above it leans toward the center. Make sure that no batteries are overhanging the waffleboard or sheets of cardboard.

7. Stud post batteries (Marine, Group 31, Golf Car) should be on the top layer. If this is not possible, you will need extra layers of cardboard between the layers of batteries to prevent punctures. This is also important when stacking three layers high.

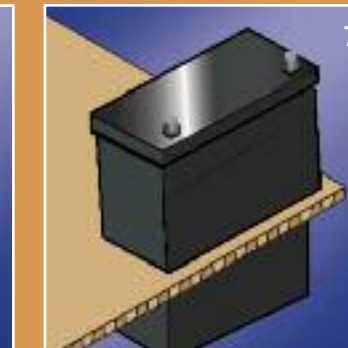
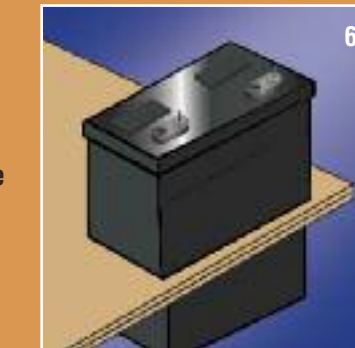

8. Damaged batteries that are not visibly leaking electrolyte must be put in heavyweight polyethylene plastic bags (minimum: 6 mil), properly sealed with plastic tie and placed in the middle of the top layer.

